

GENERAL PRODUCT INFORMATION

BASIC DATA

Product code	1010
Shape	Round
Lid type	Standard
Weight	4.0 g.

DIMENSIONS

Size	Ø 95
D1	91.3 mm.
D2	87.3 mm.
H1	2.6 mm.
H2	7.2 mm.

MATERIAL

Raw material	Polypropylene
Temperature	Temperature on request
Colour	Colour on request

CLOSURE

Closure system	Tamper evident closure
	Snap-on
	Protective collar

IML DECORATION

IML	Yes
Offset print	Yes
D3	80.5 mm.

Note: Please enquire about specific print-layouts

TUB OPTIONS

2016

Note: Please find the datasheets on our website: www.toppac.dk

TOLERANCES

Weight	± 10% ± 0.4 g.
Dimensions	± 1%

LID ROUND 1010

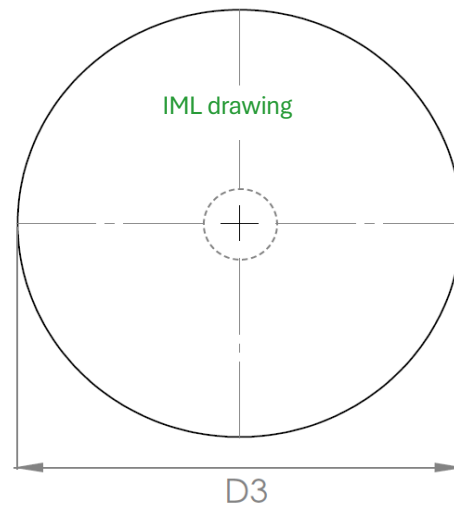

STANDARD PACKAGING

Lids/box	Units/pallet	Qty./pallet
2.832	12	33.984

PACKAGING SIZE

Unit	Size
Box	590 x 400 x 360 mm.
Pallet	1200 x 800 x 1230 mm.